

SlimBeam

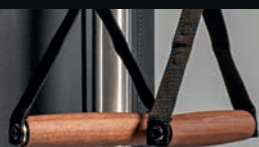

1 ARTICLE BASE

Art. No. 15172

From : 1 899 €

2 CHOICE OF WOOD



3 CHOICE OF STITCHING PATTERN

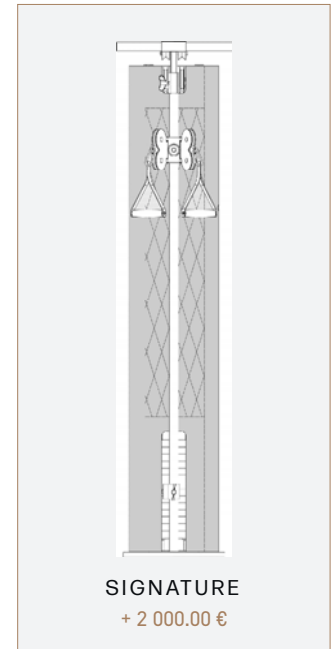
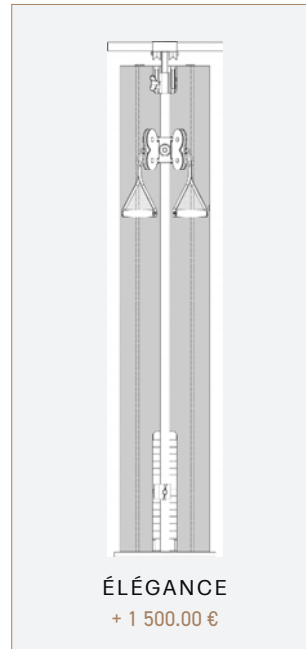
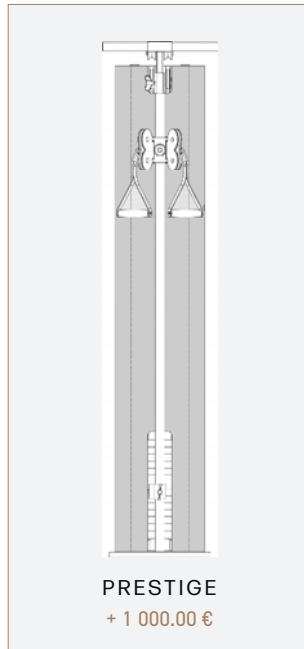
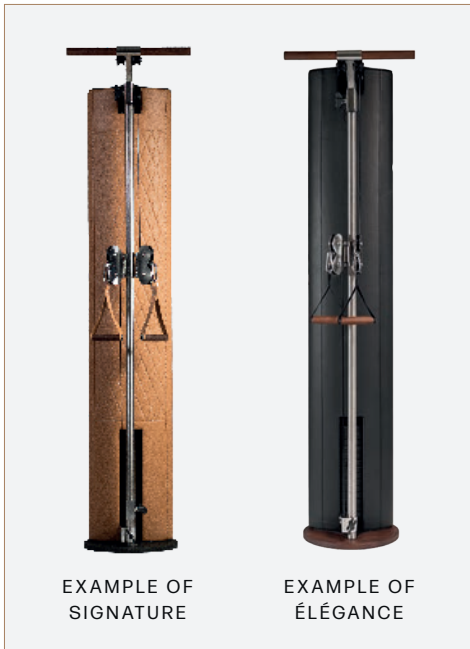

4 CHOICE OF LEATHER

4bis

LEATHER AND STITCHING COLOR

See the leather page

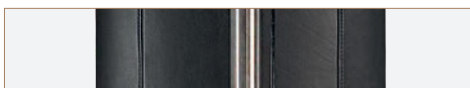

ALVA

+ 0.00 €

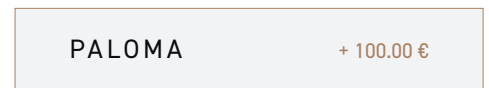

PALOMA

+ 100.00 €

5 CHOICE OF STEEL PARTS

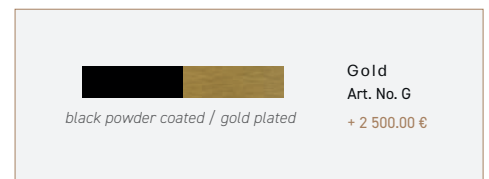
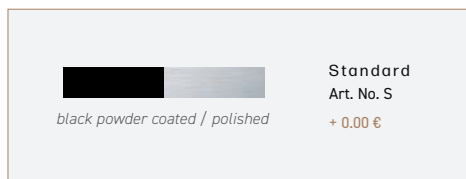
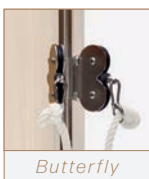
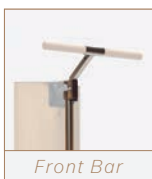

20 x 40 x 215 cm



120 kg



100 kg

WeightBench



1 ARTICLE BASE

Art. No. 25415

From : 899 €

2 CHOICE OF WOOD

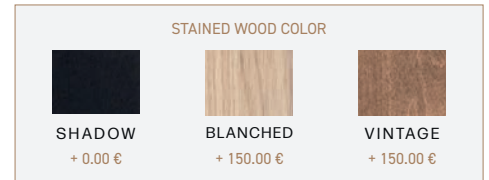

3 CHOICE OF STITCHING PATTERN

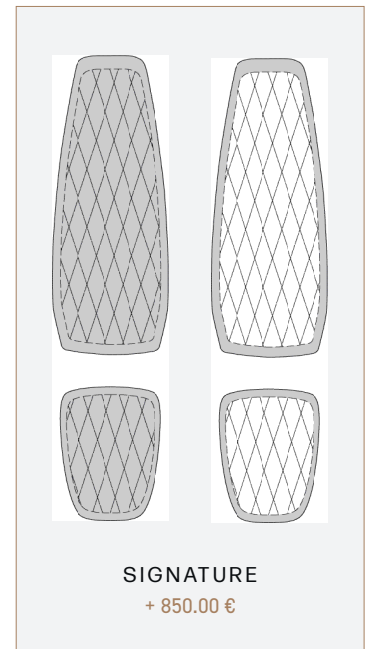
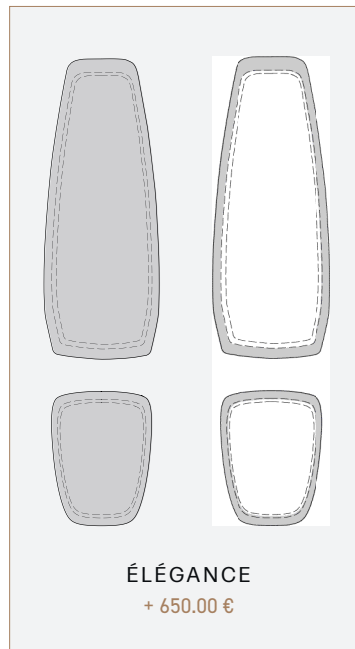
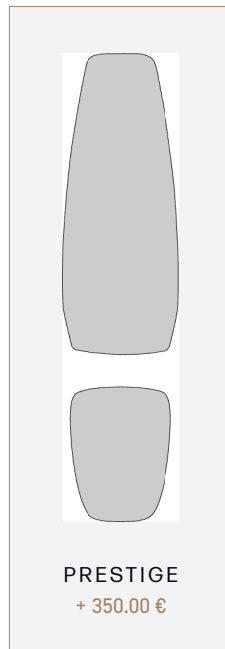

4 CHOICE OF LEATHER

4bis

LEATHER AND STITCHING COLOR

See the leather page



ALVA

+ 0.00 €

PALOMA

+ 75.00 €

5 CHOICE OF STEEL PARTS



black powder coated / polished

Standard

Art. No. S

+ 0.00 €



135 x 35 x 44 cm



20 kg



400 kg

NOHRD Wall Compact



1 ARTICLE BASE

Art. No. 24113

From : 7 899,00 €



2 CHOICE OF WOOD



NATURAL WOOD

		
OAK + 500.00 €	CHERRY + 1 100.00 €	WALNUT + 1 500.00 €

STAINED WOOD COLOR

		
SHADOW + 0.00 €	BLANCHED + 800.00 €	VINTAGE + 800.00 €

3 CHOICE OF STITCHING PATTERN

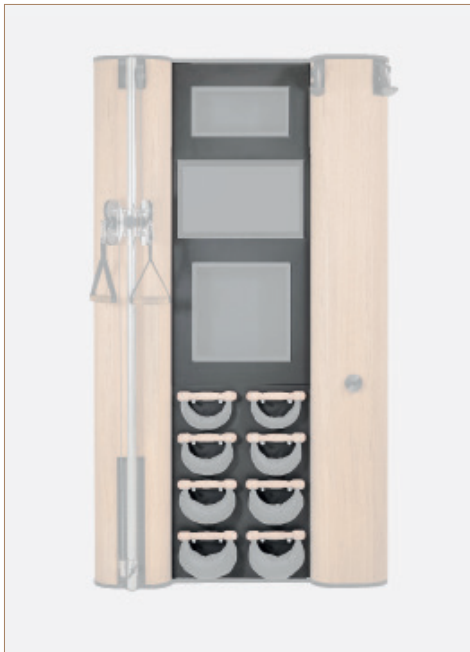
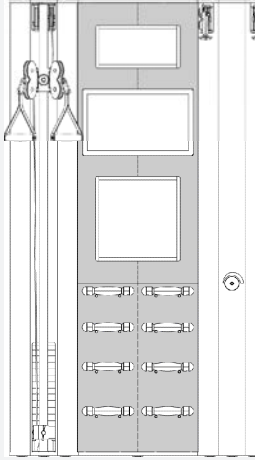
PRESTIGE
+ 1 200.00 €

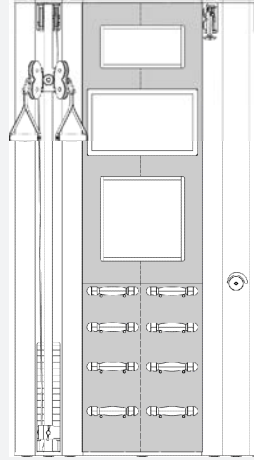

ÉLÉGANCE
+ 1 700.00 €

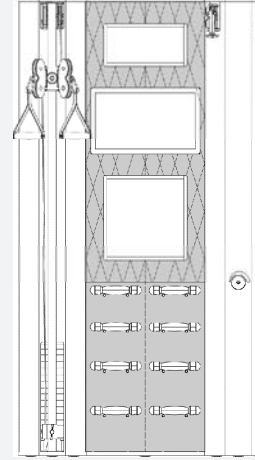

SIGNATURE
+ 2 200.00 €

4 CHOICE OF LEATHER

4bis

LEATHER AND STITCHING COLOR

See the leather page



ALVA



+ 0.00 €



PALOMA

+ 100.00 €

5 CHOICE OF STEEL PARTS



		Standard Art. No. S + 0.00 €
<i>black powder coated / polished</i>		

		Gold Art. No. G + 2 500.00 €
<i>black powder coated / gold plated</i>		



121,5 x 217 x 50 cm



250 kg



150 kg

TriaTrainer



1 ARTICLE BASE

Art. No. 19137

From : 529,00 €

2 CHOICE OF WOOD



NATURAL WOOD

		
OAK + 100.00 €	CHERRY + 250.00 €	WALNUT + 400.00 €

STAINED WOOD COLOR

		
SHADOW + 0.00 €	BLANCHED + 200.00 €	VINTAGE + 200.00 €

3 CHOICE OF STITCHING PATTERN

PRESTIGE
+ 300.00 €

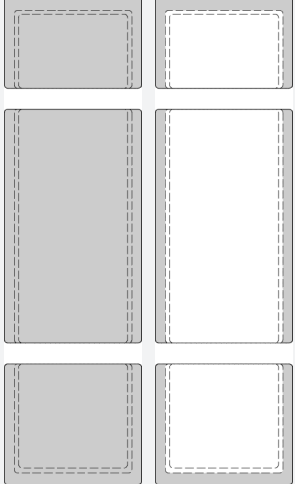

ÉLÉGANCE
+ 600.00 €

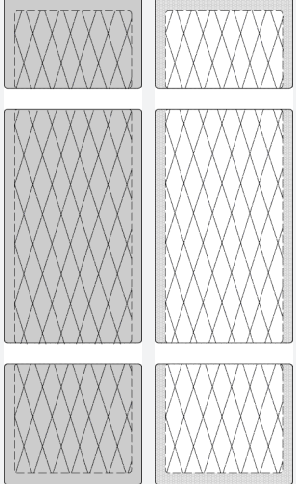

SIGNATURE
+ 800.00 €

4 CHOICE OF LEATHER

4bis

LEATHER AND STITCHING COLOR

See the leather page



ALVA



+ 0.00 €

PALOMA



+ 65.00 €

5 CHOICE OF STEEL PARTS



 
black powder coated / polished

Standard
Art. No. S
+ 0.00 €

 
black powder coated / gold plated

Gold
Art. No. G
+ 1 750.00 €



55 x 90 x 35 cm



14 kg



120 kg

NOHRD StepBox

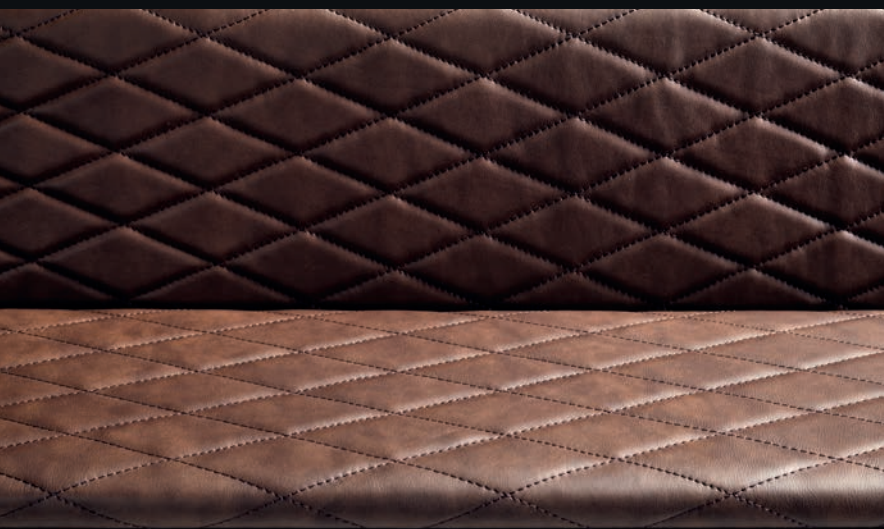

Refined by
FABRIK

1 ARTICLE BASE

Art. No. 36009

From : 2 899,00 €

2 CHOICE OF WOOD



NATURAL WOOD



OAK
+ 100.00 €



CHERRY
+ 200.00 €



WALNUT
+ 250.00 €

STAINED WOOD COLOR



SHADOW
+ 0.00 €



BLANCHED
+ 150.00 €



VINTAGE
+ 150.00 €

3 CHOICE OF STITCHING PATTERN

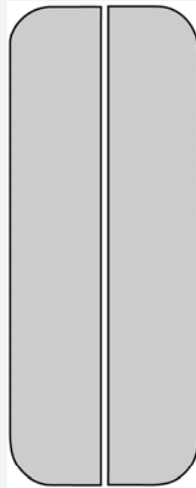

PRESTIGE
+ 280.00 €

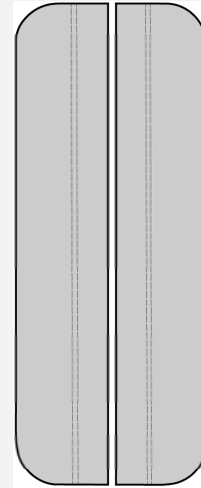

ÉLÉGANCE
+ 580.00 €

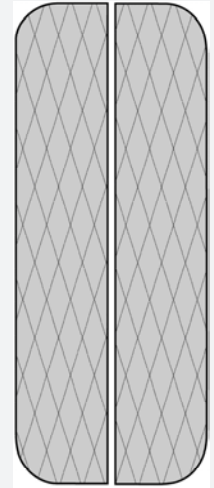

SIGNATURE
+ 780.00 €

4 CHOICE OF LEATHER

4bis

LEATHER AND STITCHING COLOR

See the leather page



ALVA

+ 0.00 €

PALOMA

+ 85.00 €



121 x 57 x 45,5 cm



80 kg



150 kg

NOHRD StepTower



Refined by
X FABRIK

1 ARTICLE BASE

Art. No. 36114

From : 4 749,00 €

2 CHOICE OF WOOD



NATURAL WOOD



OAK
+ 100.00 €



CHERRY
+ 200.00 €



WALNUT
+ 250.00 €

STAINED WOOD COLOR



SHADOW
+ 0.00 €



BLANCHED
+ 150.00 €



VINTAGE
+ 150.00 €

3 CHOICE OF STITCHING PATTERN

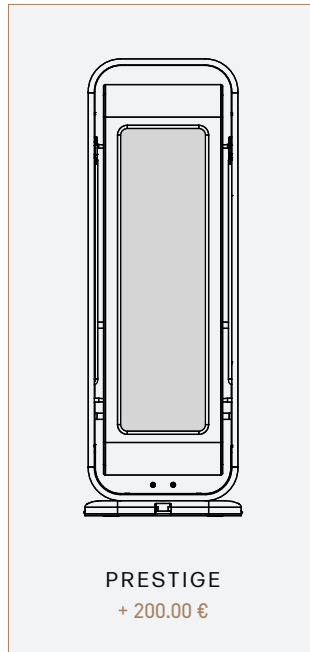

PRESTIGE
+ 200.00 €

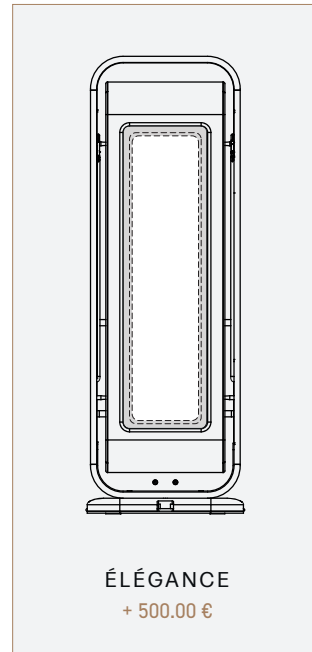

ÉLÉGANCE
+ 500.00 €

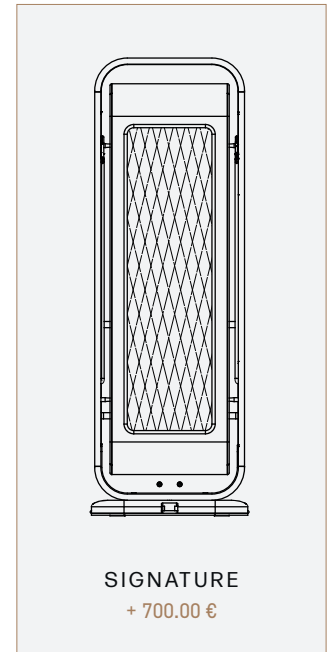

SIGNATURE
+ 700.00 €

4 CHOICE OF LEATHER

4bis

LEATHER AND STITCHING COLOR

See the leather page



ALVA

+ 0.00 €

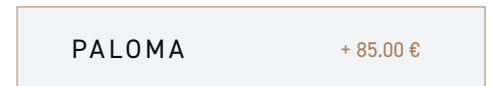

PALOMA

+ 85.00 €



121 x 57 x 45,5 cm



80 kg



150 kg

WeightPlate Tower



Refined by
X FABRIK

1 ARTICLE BASE



Art. No. 26008

From : 2 749,00 €



2 CHOICE OF WOOD



NATURAL WOOD

		
OAK + 100.00 €	CHERRY + 620.00 €	WALNUT + 920.00 €

STAINED WOOD COLOR

		
SHADOW + 0.00 €	BLANCHED + 400.00 €	VINTAGE + 400.00 €

3 CHOICE OF STITCHING PATTERN

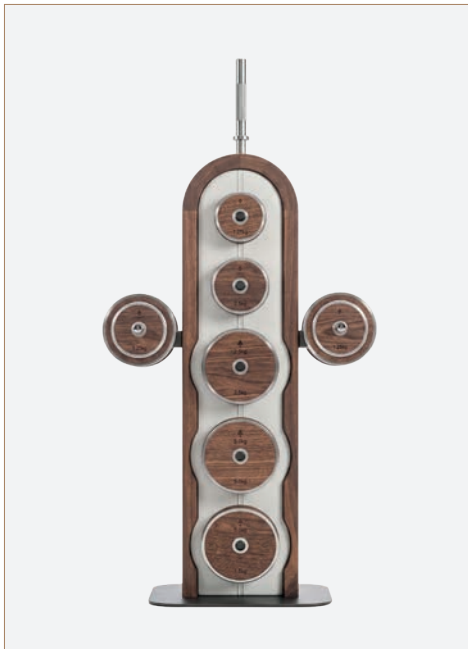
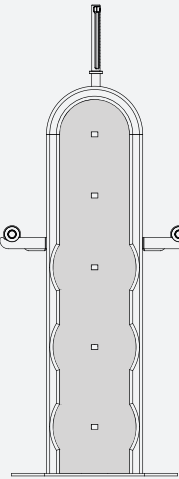
PRESTIGE
+ 200.00 €

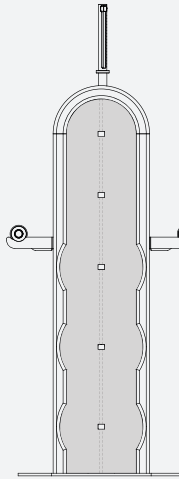

ÉLÉGANCE
+ 500.00 €

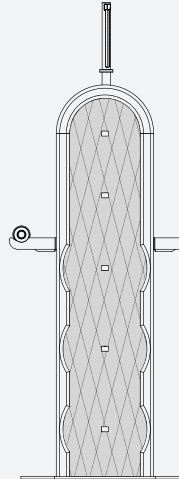

SIGNATURE
+ 700.00 €

4 CHOICE OF LEATHER

4bis

LEATHER AND STITCHING COLOR

See the leather page



ALVA + 0.00 €

PALOMA + 85.00 €



45 x 45 x 117 cm



88 Kg

YA'FI



Y'FABRIK
Atelier Français

1 ARTICLE BASE

Art. No. 29.1

From : 2 099,00 €

3 CHOICE OF STITCHING PATTERN



EXAMPLE OF
ÉLÉGANCE

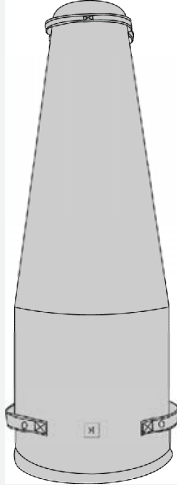

PRESTIGE
+ 0.00 €

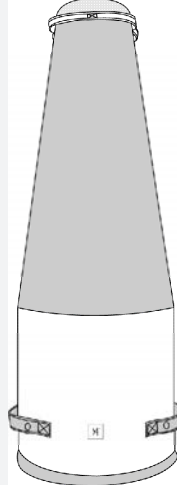

ÉLÉGANCE
+ 200.00 €

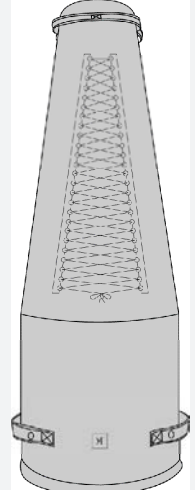

SIGNATURE
+ 400.00 €

4 CHOICE OF LEATHER

4bis

LEATHER AND STITCHING COLOR

See the leather page



ALVA

+ 0.00 €

PALOMA

+ 150.00 €



175 x ø 60 cm



75 Kg

YA'FIGHT



1 ARTICLE BASE

Art. No. 29.5

From : 1 359,00 €

3 CHOICE OF STITCHING PATTERN



EXAMPLE OF
SIGNATURE

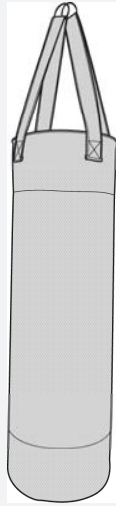

PRESTIGE
+ 0.00 €

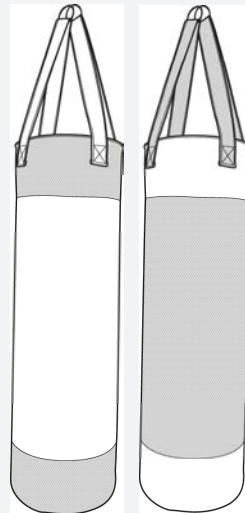

ÉLÉGANCE
+ 200.00 €

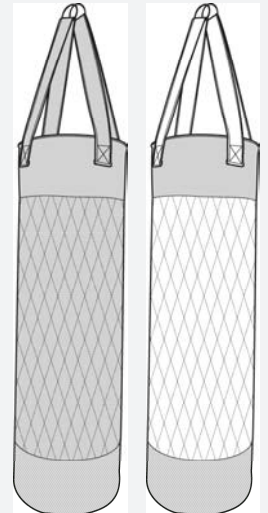

SIGNATURE
+ 400.00 €

4 CHOICE OF LEATHER

4bis

LEATHER AND STITCHING COLOR

See the leather page



ALVA

+ 0.00 €

PALOMA

+ 100.00 €



175 x ø 60 cm



75 Kg

YA'ELASKO



1 ARTICLE BASE

Art. No. 29.4

From : 199,00 €

3 CHOICE OF STITCHING PATTERN



EXAMPLE OF
ÉLÉGANCE

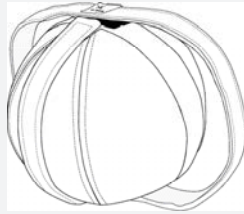
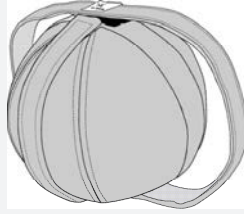

PRESTIGE
+ 0.00 €

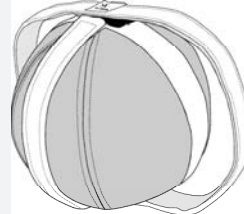

ÉLÉGANCE
+ 30.00 €

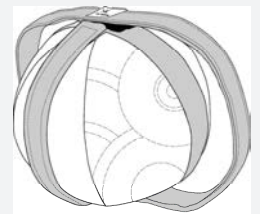
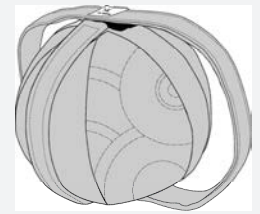

SIGNATURE
+ 80.00 €

4 CHOICE OF LEATHER

4bis

LEATHER AND STITCHING COLOR

See the leather page



ALVA

+ 0.00 €

PALOMA

+ 20.00 €



ø 19 cm



0,7 kg

YA'FU



1 ARTICLE BASE

Art. No. 29.2

From : 149,00 €

3 CHOICE OF STITCHING PATTERN



EXAMPLE OF
SIGNATURE

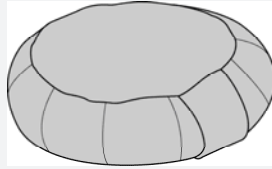

PRESTIGE
+ 0.00 €

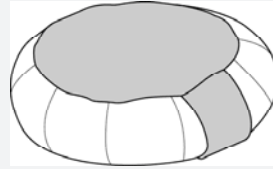

ÉLÉANCE
+ 20.00 €

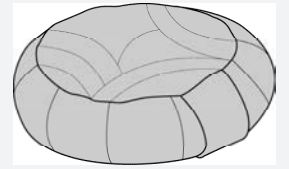

SIGNATURE
+ 50.00 €

4 CHOICE OF LEATHER

4bis

LEATHER AND STITCHING COLOR

See the leather page



ALVA

+ 0.00 €

PALOMA

+ 20.00 €



175 x ø 60 cm



75 Kg

EMBROIDERY & PRINTING



Pñoe
Breathing Life



Refined by
X FABRIK

1 EMBROIDERY



Personalise your equipment with embroidery crafted in our workshops.

Company logo, initials or signature phrase: every design is faithfully reproduced on leather using premium threads, for a luxurious and long-lasting finish.

2 LASER ENGRAVING



Laser engraving etches your design directly into the cork with sub-millimetre precision. Ink-free and flush with the surface, it reveals the raw texture of the material for an elegant, permanent and distinctly natural signature.

3 PRINTING



Reproduce even your most complex visuals on cork with high-definition printing. Perfect for multicolour logos, gradients or photographs, this technique delivers a vivid, photo-quality result directly onto the surface of the material.

Alva :



BLACK1000



BROWN2000

Paloma :



ARTIC
55200



BLACK
05599



CEDAR
05503

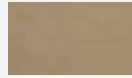

PARCHMENT
20010



TAN
05360



CHARCOAL
55206



LIPSTICK
20076



EMERALD
55125



SUPER WHITE
05500



WHITE
20054



IVORY
05522



TAUPE
20000



SAFARI
20058



PUMICE
20101



BARK
05507



HARVEST
20132



CAMEL
20005



SIERRA
20174

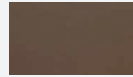

DUNE
05803



CINNAMON
05506



TOBACCO
56046



MAROON
55130

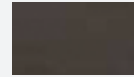

CHOCOLATE
56059



NATURE
05429



TERRA
55113



DARK BROWN
05509



LIMON
55232



CITRUS
55230



HENNA
55188



POPPY
05106



RUBINO
55112



RASPBERRY
55127

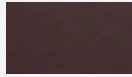

CHATEAU
56021



AQUA
55229



CARIBBEAN
20098



GRANITE
20015



INDIGO
56022



OCEAN
05853

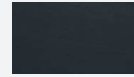

ATLANTIC
20050



NAVY
20011



MARINA
55114



COBALT
05710



SKY BLUE
55233



PURPLE
55231



LAGOON GREEN
05518



PISTACHIO
55189



CLOVER
56036



SMARAGD
05711



WOOD
05851



OLIVE
20073



HUNTER
20074



CHAMPAGNE
05489



MODE
05524



HAZE
20030



GREY
20002



SEAL
20082



GREY BROWN
55205



ANTRA
55115



SMOKE
55132

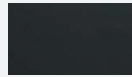

NIGHTSHADE
55185

Color of stitching :

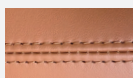

TONE-ON-TONE



BLACK
4000

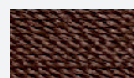

BROWN
3542

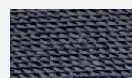

DARK GREY
1488

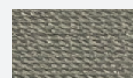

LIGHT GREY
3525

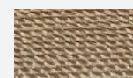

BEIGE
3590

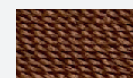

CAMEL
900

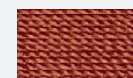

ORANGE
1288

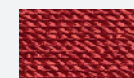

RED
2455

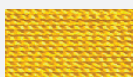

YELLOW
3329

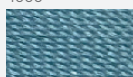

BLUE
272

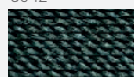

GREEN
2749

PALOMA LEATHER

PALOMA leather is elegant, smooth and timeless. It's a slightly corrected semi aniline leather with a warm and soft touch. Semi-aniline leather is a lightly sanded leather that is supple and soft, with an elegant look. The leather may be lightly patterned or retain its natural grain, which is slightly stronger than with full-grain semi-aniline leather. Sitting comfort remains high, as the ability of the leather to breathe is partially preserved.

PALOMA leather is free of chrome and produced without PCP and CFC and fulfils the requirements according to BS5852 CRIB 5.

YA'FABRIK **PALOMA** comes in 60 selected colours, in order to best match your design taste.

TECHNICAL SPECIFICATIONS

Average size : 4,8 m2
Thickness: 1,0-1,2 mm
Raw material: European raw hides
Tanning: Chrome-Free

	METHOD	TEST RESULT
Light Fastness	DIN EN ISO 105-B02	≥6
Colour Fastness to Rubbing (Dry) : 500 Cycles	DIN EN ISO 11640	≥4
Colour Fastness to Rubbing (Wet) : 80 Cycles	DIN EN ISO 11640	≥4
Colour Fastness to Sweat : 50 Cycles	DIN EN ISO 11640	≥4
Tear Strength	DIN EN ISO 3377-1	≥20 N/mm
Flex Endurance	DIN EN ISO 5402	30.000
PH Value	DIN EN ISO 4045	≥3,5
Finisih Adhesion	DIN EN ISO 11644 / 5402	≥2,5 N/cm

Chrome-free tanned and without the use of PCP and CFC which are damaging to the environment.

PALOMA leather is Chrome-free (FOC) and complies with the standard for the REACH declaration.

Flame resistance:

The material fulfills the requirement according to:

- UNI EN ISO 1021-1/2
- BS5852 Crib 5
- ÖNORM B3800
- ÖNORM B3825
- DIN 5510-2 «Papierkissen-Test»
- IMO-Res. A 652 (16)
- California T.B. 117-2013 section 1



ALVA LEATHER

The leathers with reference 20017 and 20104 (2068) are soft and pliable semi-aniline-leathers. Outstanding comfort combined with excellent durability and an extensive shade card, makes it very suitable for the public environment.

Visible insect bites and scars from healed wounds, add to the genuine character of the leather.

TECHNICAL SPECIFICATIONS

Raw material : Grain leather from Scandinavian cattle
Thickness : 1,1-1,3 mm

The leather is dyed and tested at the tanneries' laboratory. A hide is selected at random from every batch of finished leather and checked in accordance with the following:

	METHOD	TEST RESULT
Light Fastness	ISO 105-B02	6
Colour Fastness to Rubbing (Wet) : 80 Cycles	ISO 11640	80/4
Colour Fastness to Rubbing (Dry) : 500 Cycles	ISO 11640	2000/4
Colour Fastness to Sweat : 50 Cycles	ISO 11640	50/4
Finisih Adhesion	ISO 11644	2 N/cm
Tear Strength	ISO 3377-1	20 N

Colour assessment: Daylight source D 65, closely corresponding to CIE standard light D65

Flame resistance:

- The material fulfills the requirement according to:
- ISO 8191-1&2
- EN 1021-1&2
- California TB 117
- BS 5852 CRIB 5
- ECE R118
- IMO 2010 FTP CODE Part 8